



LASER 3D-SCOPIC PROJECTION

HDI System Specification (Rev 5)

Attribute	Specification
Product:	HDI 3DTV System
<i>System Type:</i>	HDI Peripheral Projection Technology
<i>Screen Size:</i>	70" - 120" Diagonal
<i>Aspect ratio:</i>	16 : 9
<i>Cabinet Depth:</i>	7" – 12" (10:1 ratio)
<i>Light Source Type:</i>	RGB Laser
<i>Picture Resolution:</i>	1920x1080p
<i>2D/3D:</i>	Built-in 3D Optical Engine Design allows seamless change from 2D to 3D
<i>Imagers:</i>	Dual Panel LCOS (x2) (Two Imagers provide 4M White Pixels)
<i>Imager Native Resolution:</i>	1920Hx1080V 2M Physical Pixels/Imager (x2)
<i>Picture Brightness:</i>	100-170 nits (30-50 ft-L) (screen gain dependant)
<i>Picture Contrast Ratio:</i>	>1500:1
<i>Engine Lumen Output:</i>	800 - 2400 lumens
<u>Laser Light Source</u>	
<i>Lasers:</i>	HDI RGB Laser Modules
<i>White Laser Power (Optical):</i>	9W (70") – 19W (120")
<i>RGB Laser Lifetime:</i>	20,000 hours
<i>Color Primaries:</i>	635nm, 532nm, 446nm
<i>Color Primary Passbands:</i>	< 2nm
<u>Optical Engine</u>	
<i>Light Source:</i>	HDI Diode Laser Modules (RGB)
<i>Imagers Size:</i>	0.81" Diagonal 16 : 9
<i>Sequential Color Switching:</i>	Field-Sequential Slit-scanned
<i>Color Refresh Frames:</i>	360 Hz.
<i>Color Temperature:</i>	6500° K - 9800° K
<i>White point:</i>	D65 standard up to 10° K
<i>Color gamut:</i>	Up to 200% NTSC
<i>Output Polarization:</i>	R _L G _L B _L = circular left R _R G _R B _R = circular right
<i>Lumen & Dark uniformity</i>	95%, 95%
<i>Image distortion & linearity</i>	0.2% & 0.3%
<i>Lateral color dispersion</i>	½ pixel
<i>Color convergence Error:</i>	None
<u>3D</u>	
<i>3D Type:</i>	Polarization-based Field-Continuous Parallel Stereo Pair
<i>Separation Method:</i>	Passive Glasses, Polarization Preserving Screen
<i>Polarization Type:</i>	Circular polarization
<i>Active Components:</i>	None
<i>Stereo Resolution:</i>	2M pixel left-eye Imager + 2M pixel right-eye. Imager provides 4M pixel stereo <u>without sequential switching</u> .
<i>Content Frames:</i>	60 left content frames/sec. + 60 right content frames/sec. Left and Right content frames exposed simultaneously

Power Consumption (See Plot 1 Below)



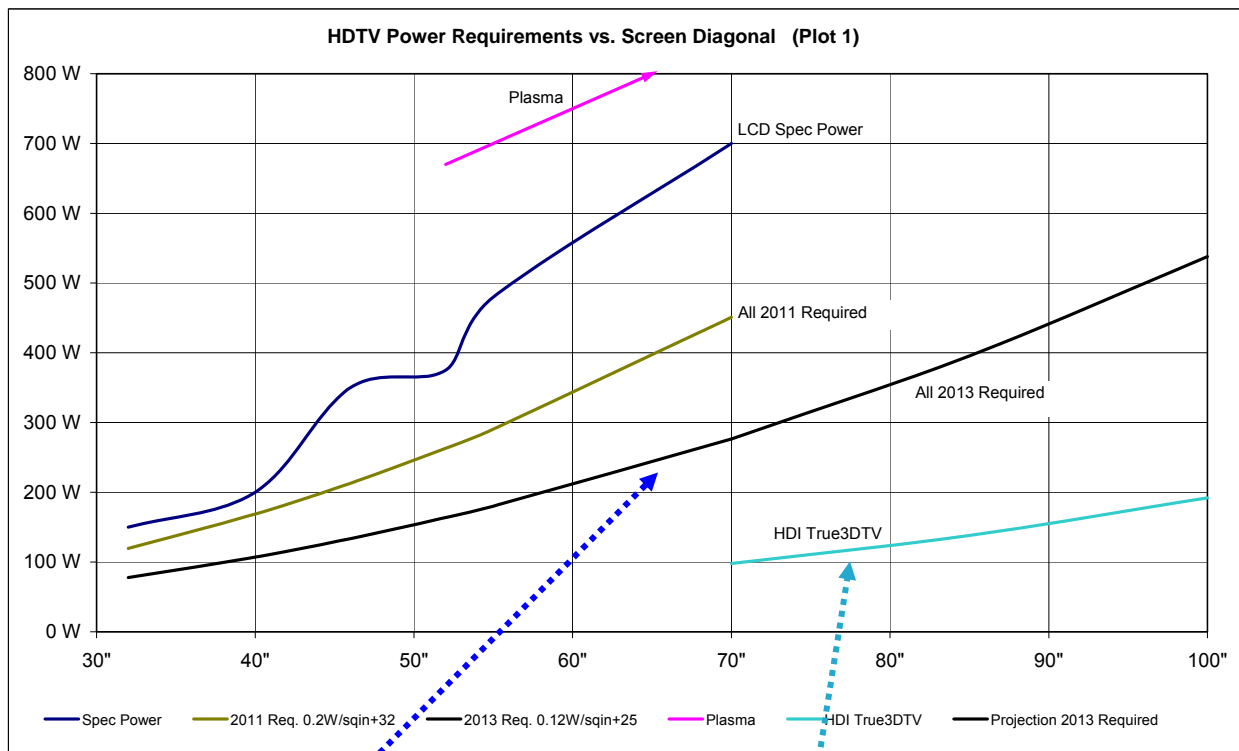

Total wall plug power: HDI True3DTV (70"): **98 W** (100"): **190 W**
 Wall watts / screen sqft. 6.5 W / Sqft.
 Spec power comparison: LCD (70"): **700 W** Plasma (70"): **920 W**
 Power / sqft. comparison: LCD (70"): **50 W/Sqft.** Plasma (70"): **83 W/Sqft.**

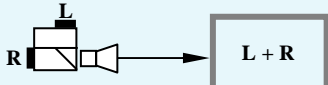

CALIFORNIA 2013 ENERGY EFFICIENCY STANDARDS!

EXCEEDS CALIFORNIA 2013 ENERGY EFFICIENCY STANDARDS!

HDI 3DTV System Competing 3D Systems Comparison

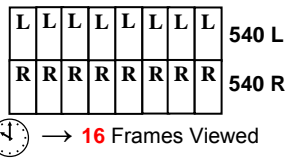
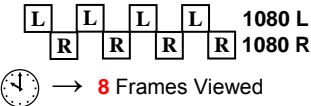
Attribute			
3D Product:	HDI 3DTV System	Interleaved 3D LCD Panel	3D Plasma, LCD & DLP
3D Technology:	L & R Continuous 3D (via HDI Peripheral Projection) Two separate full-res imagers integrated as one projector 	L & R Interleaved 3D (via structured panel polarizers) Panel pixels divided into two interleaved L & R groups 	L & R Sequential 3D (via electronic shutters) One sequential imager or flat panel switches to L then R image 
3D Native Resolution:	1920 x 1080p x 2 4M pixels continuous	1920 x 1080p 2M pixels continuous	1920 x 1080p 2M pixels sequential
3D Glasses:	Passive Polarized	Passive Polarized	Active Shuttered
3D Method:	Separate L & R images are continuously in view	Interleaved L & R images are continuously in view	L & R Images are sequentially switched into view
3D Performance Impact:	<u>No Loss</u> Full Resolution, Full Temporal	<u>Half Spatial Resolution Loss</u> Half Resolution, Full Temporal	<u>Half Temporal Resolution Loss</u> Full Resolution, Half Temporal
3D Content Density:	Content Frames  → 16 Frames Viewed	Content Frames  → 16 Frames Viewed	Content Frames  → 8 Frames Viewed
3D Total Content Density:	248M 3D pixels/sec Viewed	124M 3D pixels/sec Viewed	124M 3D pixels/sec Viewed
		Physiological Factors	
3D Picture Brightness:	+50% No Polarization Loss	-50% Polarization Loss	-50% Sequential On-time Loss
3D Line Aliasing:	Minimal (1080 lines)	Significant (540 lines)	Moderate (1080 lines half-speed)
3D Frame Refresh:	360 Hz	120 Hz	120 Hz
3D Pair Timing Lag:	None	None	Significant (L-R Sequential Timing Lag)
3D Waste Spatial Frequency:	None	Interleaved image and panel structures	None
3D Physiological & Eye Strain Issues Summary:	None	High spatial frequency structures Line Aliasing Brightness Loss Slower frame Refresh	Sequential Timing Lag Line Aliasing Brightness Loss Slower frame Refresh